



USE AND CARE GUIDE

MOTORIZED MOTION TRACKING LED SECURITY LIGHTING

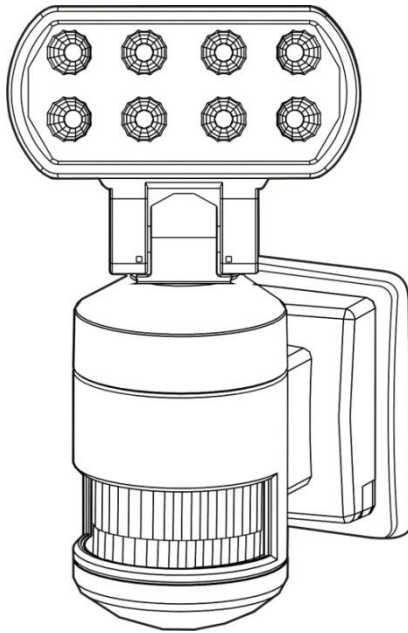

Table of Contents

| | | | |
|----------------------------|---|----------------------------------|-----|
| Table of Contents..... | 2 | Tools and Hardware Required..... | 3 |
| Safety Information | 2 | Package Contents | 4 |
| Warranty | 2 | Specifications | 4 |
| What Is Covered..... | 2 | Installation..... | 5 |
| What Is Not Covered..... | 2 | Operation..... | 6-7 |
| Pre-Installation..... | 3 | Care and Cleaning..... | 8 |
| Planning Installation..... | 3 | Troubleshooting..... | 8 |

Safety Information

1. This device complies with Part 15 of the FCC Rules. Operation is subject to the following two conditions: (1) this device may not cause harmful interference, and (2) this device must accept any interference received, including interference that may cause undesired operation.
2. The installation of this light fixture must be done by a qualified electrician.
3. The motion sensor may not operate correctly if it is installed:
 - Near the outlet of a central heating boiler.
 - Near an air condition unit.
 - Pointing directly at moving vehicles.

- Within sight of reflection from moving water.
- Where other lights could be pointed onto the sensor.



WARNING:
Changes or modification to this unit not expressly approved by the party responsible for compliance could void the user authority to operate the equipment.



CAUTION:
Do not immerse the light fixture in water.
Do not mount the light fixture against flammable surfaces.



IMPORTANT:
This light fixture must be grounded.

Warranty

12 MONTH WARRANTY

WHAT IS COVERED

12 month limited warranty from date of purchase. Please retain proof of purchase. The manufacturer reserves the right to replace or repair the faulty unit.

WHAT IS NOT COVERED

The warranty does not cover damage to the unit that may occur as a result of improper installation. This product is designed to illuminate, it will not prevent the perpetration of any act, legal or illegal. The manufacturer assumes no liability for any damage to property, injury to person, or death.

Please feel free to contact us at service@versonel.com with any questions or visit us at www.versonel.com

Pre-Installation

PLANNING INSTALLATION

Never attempt to turn the light head by hand as this can damage the internal motor components.



NOTE:

Before attempting any installation or maintenance, ensure that the electrical supply is switched off and the circuit fuses removed or the circuit breaker is in the "OFF" position.

TOOLS REQUIRED



Hammer



Safety goggles



Phillips screwdriver



Level

HARDWARE REQUIRED



NOTE: Hardware not shown to actual size.

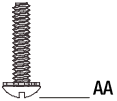

AA

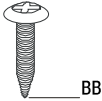

BB



CC



DD

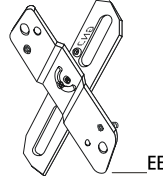

EE

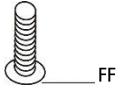

FF

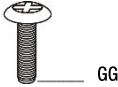

GG

| Part | Description | Quantity |
|------|------------------------|----------|
| AA | Mounting screw | 2 |
| BB | Drywall screw | 2 |
| CC | Plastic masonry anchor | 2 |
| DD | Wire nut | 3 |
| EE | Cross bar | 1 |
| FF | Base bracket screw | 1 |
| GG | Screw | 2 |

Pre-Installation (continued)

PACKAGE CONTENTS



NOTE:

The intelligent motion sensor tracking light is designed to illuminate when the detection area is entered by a person and will detect a moving heat source. There is no guarantee implied that it will provide total security or prevent illegal entry.

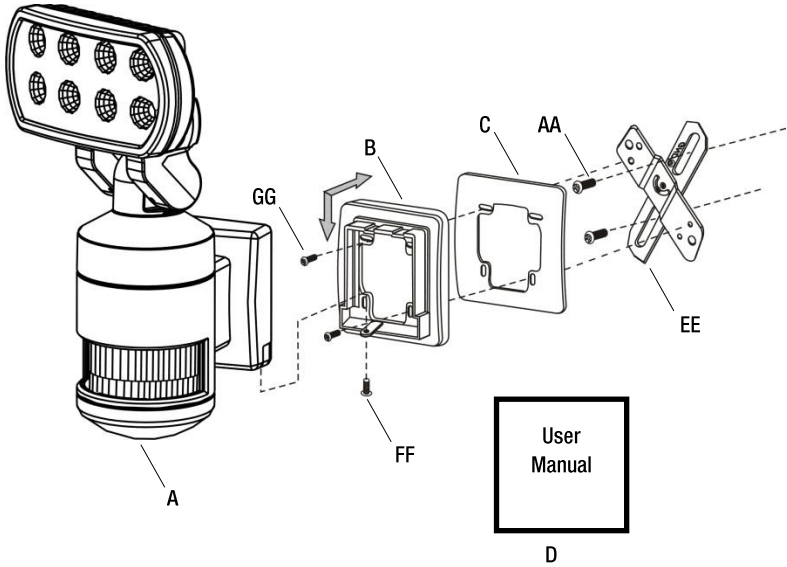

| Part | Description | Quantity |
|------|---------------|----------|
| A | Light fixture | 1 |
| B | Base bracket | 1 |
| C | EVA gasket | 1 |
| D | User manual | 1 |

SPECIFICATIONS

| | |
|------------------|--|
| Detection Method | Passive infrared sensor (with continuously detect function) |
| Sensor Range | Up to 36.3ft x 220° |
| Power Source | AC120V 60Hz |
| Light Source | Nichia 120lm 1W LED x 8 |
| Time Adjustment | Fixed at 3 minutes approx. |

Installation

1 Mounting the light fixture



DANGER:
Incorrect voltage may cause electric shock. If you are not sure, please contact your retailer.



CAUTION:
Do not remove the tape until you finish the installation. If the tape comes off the light, please replace it or hold the light head to avoid swiveling and damage to the product.



CAUTION:
LED lamps are extremely bright. Under no circumstances should you stare into an LED beam since this may cause irreparable damage to the eye.



IMPORTANT:
Please make sure the voltage and polarity are correct before connection.



NOTE:
To ensure correct operation of the sensor, mount the light fixture so that the traffic passes across the detector.

- Remove the existing light fixture. Install the cross bar (EE) lower plate as shown with two screws (AA).
- Remove the base bracket (B) from the light fixture (A). Align the base bracket (B) with the EVA gasket (C) and a cross bar (EE) upper plate and secure it with two screws (GG) which are already attached on the cross bar (EE). Make sure the base bracket (B) is straight.
- Tighten the two central screws and one base bracket screw (FF). Do not use excessive force. The recommended installation height of this light fixture is between 6.5-10ft.

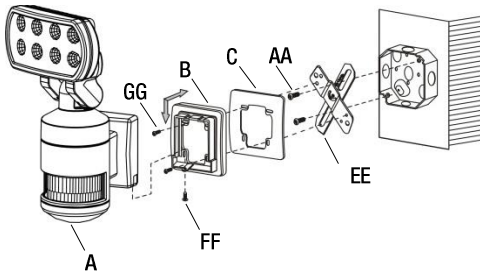

2 Wiring the light fixture



DANGER:
Check that all connections are correct and tight, as any misconnections will damage the motion sensor or cause a fire hazard.

- Feed the cable through the base bracket (B).
- Connect the black wire (live wire) from the AC power cord to the single black wire coming from the light fixture (A) using one of the supplied wire nuts (DD).
- Connect the white wire from the AC power cord to the single white wire coming from the light fixture (A) using one of the supplied wire nuts (DD).
- Connect the green/yellow wire from the AC power cord to the single green/yellow wire coming from the light fixture (A) using one of the supplied wire nuts (DD).
- Re-fit the light fixture (A) to the base bracket (B).

Black to black (L)

White to white (N)

Green/yellow to green/yellow

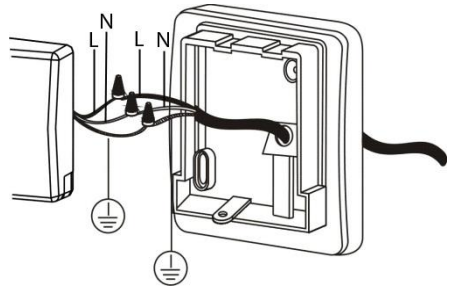

Operation

1 Detection range

- This light is equipped with three motion sensors: zone 1 covers 60 degrees, zone 2 covers 100 degrees and zone 3 covers 60 degrees. There is a 220 degree maximum total in all three zones.

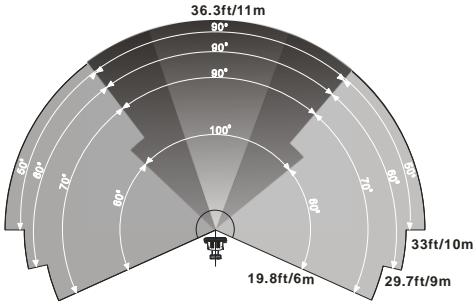

2 Function

- When power is first turned on the light will go to self-calibration mode for about 1 minute.
- During calibration mode the light will switch on for 1 minute to test bulb activity.
- If calibration was done during day time – the light will automatically go to stand-by mode until dusk.
- If calibration was done during night time – the light will resume normal operation.
- The factory default setting is:
 - **Night Mode:** the light will turn on for 3 minutes when heat/movement is detected through the front lens of the housing indicating system active.
- To change detection/light activity to **ALL Day Mode**, push the button at the bottom of the housing.

3 Programmable functions



NOTE:
The hidden LED indicator will be constantly red in Night Mode. The hidden LED indicator will stay off under ALL Day Mode.

- Push-button programmable functions:
 - **Night Mode:** light works at night only (factory setting)
 - **ALL Day Mode:** light works day and night

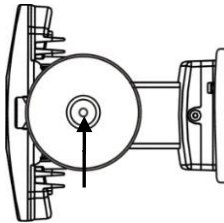

4 Reset function

- If the stepper motor of the tracking light works abnormally, the hidden LED indicator will flash red and the light will stop turning automatically.
- In **ALL Day Mode**, the red light will flash on and off for 5 seconds; in **Night Mode**, the red light will flash in regular patterns.
- Simply switch off and on at the main power supply to reset the tracking light operation. Below are the possible abnormal situations.
 - **External force:** the light head is blocked by objects or is blown by strong wind and is unable to turn properly. The hidden LED will flash in red to signal users of the abnormal situation.
 - **Stepper motor:** when the stepper motor is out of synchronization, malfunctions, or is damaged, the hidden LED will flash red to signal users of the abnormal situation. Switch off and on at the main power supply. If the stepper motor stops working, the tracking light becomes a regular motion sensor security light.

5 Testing the light fixture



NOTE:

Allow for approximately 1 minute calibration time before the sensors resume normal activity.

- Turn on the wall switch to activate the light, the light is now under Night Mode.
- To test, walk through the sensor's detection area.
- Movement will activate the sensors and turn the light on. The light will turn the light head to the detected zone for approximately 3 minutes.
- After the light is activated, **keep out of the detection area** and the light will switch off automatically after 3 minutes. The light will be activated again when detecting any movement. If there is continuous movement in the detection zone, the light will stay on until movement ceases (after 3 minutes).

6 Ensuring correct operation

- To ensure correct operation of the sensor, mount the light fixture so that the traffic passes across the motion sensor.

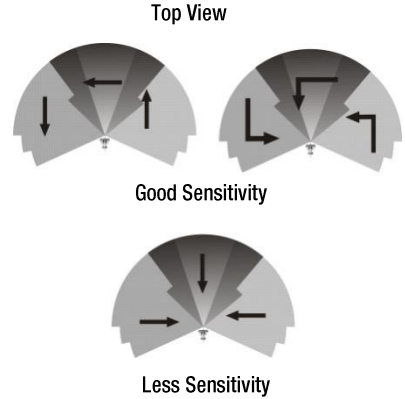

Care and Cleaning

- Use a soft lens cloth for cleaning the light front cover.
- Remove dirt or stains with a soft cloth dampened with water or neutral detergent.



IMPORTANT:

Do not open this product for unauthorized service. This could cause serious damage to the unit and will void the warranty.

Troubleshooting

| Problem | Possible Cause | Solution |
|--|--|---|
| The LED light head does not move. | The light head is blocked by objects or is blown by strong wind. | <ul style="list-style-type: none">□ Turn the circuit breaker off for about 10 seconds and then turn back on.□ The light should go through its set up routine and adjust the head for proper operation. |
| | The motor is out of synchronization, is malfunctioning, or is damaged. | |
| The light does not turn on. | The wiring is incorrect. | <ul style="list-style-type: none">□ Verify the wiring polarity is correct. |
| The light does not move and turn on at day time. | The unit is under Night Mode. | <ul style="list-style-type: none">□ Determine whether the hidden LED remains red. If it does, the unit is inNight Mode.□ Push the button at the bottom of the housing to change to ALL Day Mode. |

Retain this manual for future use.